

Important Safeguards

When using electrical appliances, basic safety precautions should always be followed, including the following:

- 1 Read all Instructions before using the TASSIMO brewer.
- 2 Do not touch hot surfaces. Use handles.
- 3 Close supervision is necessary when the appliance is used near children.
- 4 Do not operate unattended.
- 5 Do not use the TASSIMO brewer for purposes other than its intended use.
- 6 To disconnect, press the "off" switch, then remove plug from wall outlet.
- 7 Unplug from outlet when not in use and before cleaning. Allow to cool before replacing or removing parts, and before cleaning the TASSIMO brewer.
- 8 Do not operate damaged TASSIMO brewer. Do not operate the appliance with a damaged cord or plug or after the TASSIMO brewer malfunctions, or has been dropped or damaged in any manner. Return TASSIMO brewer to the nearest authorized service facility for examination, repair or mechanical adjustment.
- 9 To protect against fire, electric shock and injury to persons, do not immerse cord, plug, or body of the TASSIMO brewer in water or in any other liquid. See instruction for cleaning.
- 10 The use of accessory attachments is not recommended by the TASSIMO brewer manufacturer and may result in fire, electric shock or injury to persons.
- 11 Do not use outdoors or when standing in damp area.
- 12 Do not let cord hang over edge of table or "counter", or touch hot surfaces.
- 13 Do not place housing, water tank or rest water container (cup stand) on or near a hot gas or electric burner, or in a heated oven.
- 14 Scalding may occur if the brewing mechanism is opened during the brewing cycles.
- 15 **WARNING:** Do not remove side panels of brewer. No user serviceable parts inside. Repair must be done by authorized personnel only.

Save these Instructions

The TASSIMO machine uses a short power-supply cord to prevent the cord from tangling and to reduce the risk of tripping over a longer cord.

Extension cords may be used if care is exercised in their use.

If extension cord is used,

- 1 The marked 'electrical rating' (nominal voltage and nominal current) of the electrical rating of the extension cord should be at least as great as the electrical rating of the appliance, and
- 2 The longer cord should be arranged so that it will not drape over the countertop or tabletop where it can be pulled on by children or tripped over unintentionally.

Appliance is the grounded type. The extension cord should be a grounding-type 3-wire cord.

I Please read this instruction manual and the cleaning/descaling program short instructions carefully and keep for future reference.

This instruction manual describes various models.

Thank you for choosing the TASSIMO hot beverage system. With TASSIMO, you can enjoy your favorite drink at any time. Premium coffee, bold espresso, creamy cappuccino and latte, or even a cup of tea or hot chocolate.

Your TASSIMO machine works exclusively with specially developed discs known as TASSIMO DISCS (T DISCS). When you insert the T DISC, the machine automatically reads the bar code printed on the label. This contains exact details of the amount of water needed, as well as the brewing time and temperature required to prepare the chosen beverage. T DISCS are specially designed for use with the TASSIMO brewing system and offer perfect enjoyment, cup after cup. To ensure long-term enjoyment, please only use the T DISCS specially developed for the TASSIMO machine.

Safety instructions



WARNING

To reduce risk of fire and electric shock, do not remove the side covers. No user serviceable parts inside. Repair should be done by an authorized service person only. Do not immerse in any liquid.





- **This appliance is designed for domestic and not commercial use.**
- Connect and operate the appliance only in accordance with the specifications on the rating label.
- Do not use your TASSIMO machine if either the power cord or appliance is damaged.
- Use indoors at room temperature only. Do not use more than 2000 meters above sea level.
- Do not let children or persons with reduced mental or sensory abilities or limited knowledge and experience use the appliance, unless they are supervised or have been instructed in the use of the appliance by a person who is responsible for their safety.
- Supervise children to ensure that they do not play with the appliance.
- In the event of malfunction, unplug the appliance immediately.
- To avoid potential hazards, repairs such as replacing a damaged cord should only be performed by our service personnel.
- Never immerse the appliance or power cord in water.

To avoid the risk of scalding

- Never open the brewing unit during the brewing, cleaning or descaling process.
- Please note that the beverages are very hot when dispensed.
- Please take caution when opening the brewer mechanism clamp and handling the T DISCS as some pressure may be released and T DISCS can be hot to the touch.

Your TASSIMO machine at a glance

Before reading further, please open the folded diagram page at the start of the manual out to the left.

- 1 Cord storage compartment
- 2 On/off switch
- 3 Removable water tank
 - a Lid for water tank
 - b Float
- 4 Cup stand
 - a Drip tray
 - b Cup shelf
 - c Height adjustment
- 5 LC display
- 6 Start/stop button
- 7 Indicator lights
 - a Stand-by 
 - b Automatic 
 - c Manual 
 - d Fill tank 
 - e Descale 

- 8 Cup lighting
- 9 Lid
- 10 Brewing unit
 - a T DISC holder
 - b Piercing unit
 - c Drink outlet
 - d Bar code reading window
- 11 Storage compartment for Service T DISC and cleaning / descaling program short instructions
- 12 Service T DISC
(For first use, cleaning and descaling)
- 13 Cleaning / descaling program short instructions

Only for machines with water filtration system:

- 14 Filter cartridge holder
- 15 Filter cartridge
- 16 Memo display

We recommend that you store the Service T DISC and the cleaning / descaling program short instructions in the compartment provided at the **back** of the appliance.

First use of your TASSIMO machine

Before using your TASSIMO machine for the first time, **please remove the filter cartridge** and proceed as follows:

- ▶ Pull a suitable length of the power cord out of the storage compartment and plug it into the electrical socket.
- ▶ Remove and rinse the water tank thoroughly under running water, and fill it with cool fresh water up to the MAX mark.
- ▶ Remove the Service T DISC from its compartment at the back of the appliance.
- ▶ Now replace the water tank and push it firmly down into place.

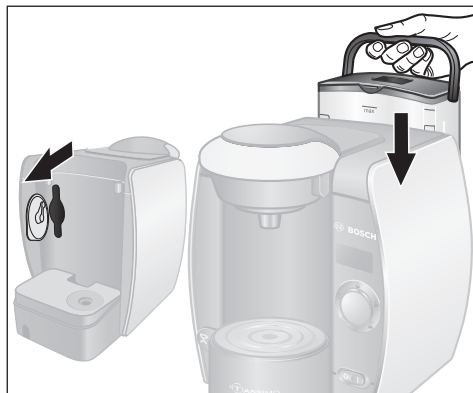
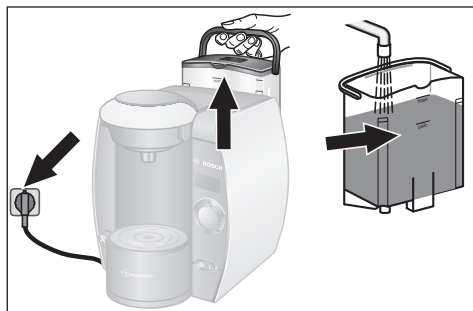



- ▶ Turn the on/off switch on (I).
All display items will light up briefly and then ⏻ Stand-by stays lit.
- ▶ Select a large cup (min. 8 oz / 200 ml) and place it on the cup shelf.

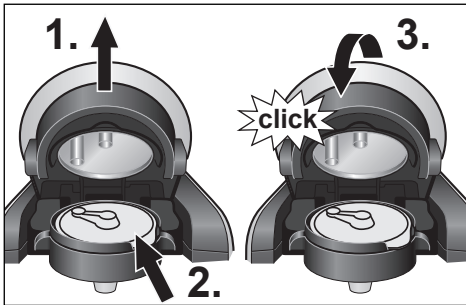

- ▶ 1. Open the brewing unit by lifting the lid.
- 2. Place the Service T DISC on the T DISC holder with the barcode facing down. Make sure that the flap of the T DISC is secured in the slot to the right.
- 3. Now close the brewing unit by pushing the lid down firmly until it audibly clicks into place.



- 4. Press the start/stop button.
The cleaning process starts and dispenses water into the cup.
- 5. When the process is complete, empty the cup and put it back on the cup stand.

⚠ Important:
Repeat steps 4 - 5 another 4 times.

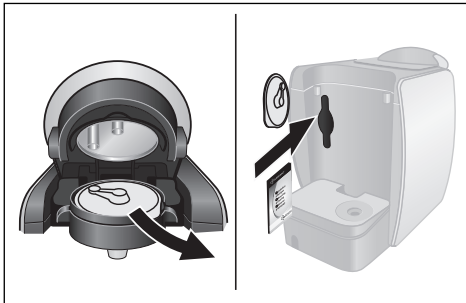

- ▶ Open the brewing unit, remove the Service T DISC and store it in the compartment at the back of the machine behind the water tank.

Only for machines with water filtration system

Only MAVEA MAXTRA water filtration system cartridges may be used in machines with a water filtration system.

The MAVEA MAXTRA cartridges may be obtained from various retailers or from TASSIMO or Bosch Customer Service Department at 1-877-TDISCS1 (1-877-834-7271) or on www.tassimo.com.

Your machine can also be operated without a filter cartridge; simply remove the filter holder and filter cartridge from the water tank.

When using a **new** filter cartridge in the machine, please observe the following procedure:

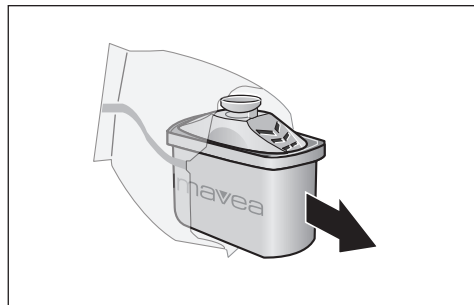

Preparing and inserting MAVEA MAXTRA filter cartridge

- ▶ Remove the filter cartridge from the protective wrap.
- ▶ Immerse the filter cartridge in cold tap water and move it gently back and forth to eliminate air bubbles (approx. 5 sec.).

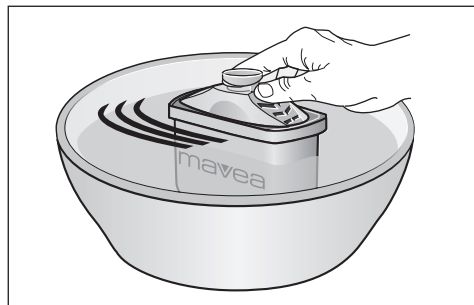

- ▶ Remove the filter holder in the water tank and insert the filter cartridge in the appropriate chamber of the filter holder; it must make a light audible click.

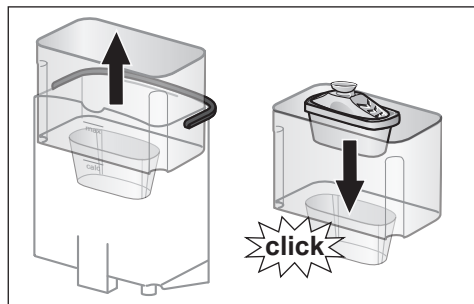

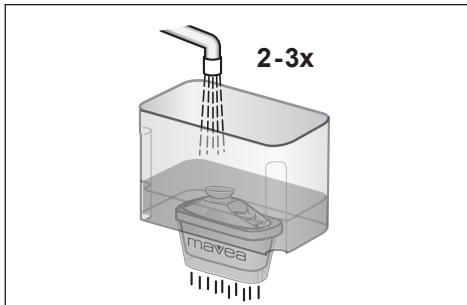

- ▶ Holding it over the sink, fill the filter holder with fresh, cold water and let it filter through.
- ▶ Please repeat this procedure two to three times.

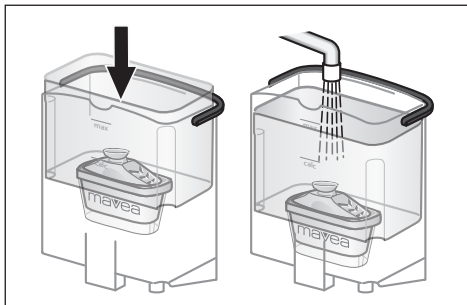

- ▶ Now place the filter holder with filter cartridge back into the water tank and fill the tank with water.

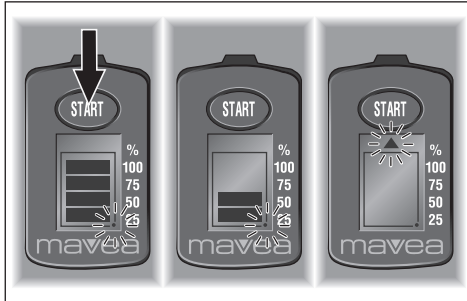

Activate MAVEA memo display

For maximum filter performance and anti-scale protection, the MAVEA MAXTRA filter cartridge must be replaced every 8 weeks.

To ensure this is done, the cover of the water tank has a built-in MAVEA memo display. It tells you by means of bars when the filter cartridge should be replaced. To activate the MAVEA memo display, please press and hold the start button until the four bars briefly light up twice in the display area.

The blinking dot in the lower right corner tells you that the memo display is working.

All four bars should be visible.

Every two weeks from activate, one bar will disappear. If no bars are visible after eight weeks and the arrow is blinking, please replace the filter cartridge.

To remove the filter cartridge, pull it upwards on its tab.

When preparing to use a new filter cartridge, please proceed as described in the section "Preparing and inserting MAVEA MAXTRA filter cartridge" and reset the MAVEA memo display.

Tip:

If only one bar is visible, please purchase a new filter cartridge.

The MAVEA MAXTRA cartridges may be obtained from various retailers or from TASSIMO or Bosch Customer Service Department at 1-877-TDISCS1 (1-877-834-7271) or on www.tassimo.com.

Your TASSIMO machine is now ready for use.

Controls and displays

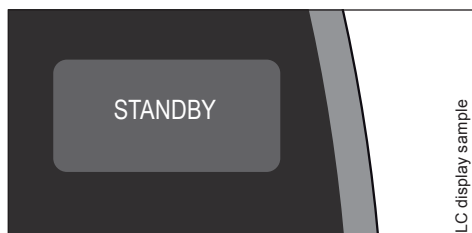

LC display sample



LC display sample

Controls

Power switch

The on/off switch turns your TASSIMO machine on stand-by and off. When it is switched on, all 5 display items light up briefly. The stand-by light  will then remain on until the appliance is in use.

i Note: To save energy, the appliance should be switched off after each use.

Start/stop button

Once the T DISC of your choice is properly secured in your TASSIMO machine, you may start brewing it by pressing the start/stop button. Press again to stop the brewing process early, in order to adjust the drink to your individual taste.

Displays

The LC display helps guide you through the process of preparing your drink. It lets you know what your TASSIMO machine is doing at every stage in the brew cycle and helps to guide you through making your hot beverage according to your individual preferences.

- ▶ While your drink is brewing, the LC display indicates graphically how much time remains before the brew cycle is completed.
- ▶ You can easily change the language setting for the LC display. Available languages are:
 - English
 - French
 - Spanish

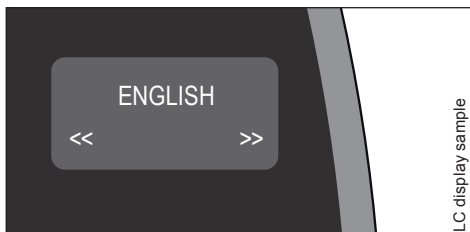

LC display sample

Language settings

To adjust the language please proceed as described:

The appliance must be in stand-by mode and ready for use (orange light must be on).

- ▶ Check that T DISC has been **removed** and brewing unit is closed.
- ▶ Press and hold the start/stop button for approximately 5 seconds. The LC display will indicate ENGLISH as the default setting.
- ▶ To change the language keep pressing the button until your preferred language is displayed.
- ▶ Please wait approximately 10 seconds and the setting is saved automatically.

Your TASSIMO machine automatically reverts to stand-by mode after setting your language preference and is now ready for use.

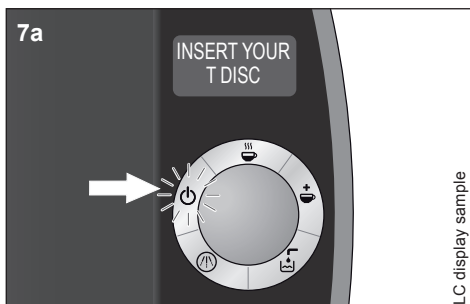

LC display sample

7a Stand-by

 Stand-by icon lights up (orange) when the power switch is switched on. Now you can open the brewing unit and insert a T DISC.



LC display sample

7b Automatic

 Automatic icon lights up (green) when your TASSIMO machine is ready for use.

 Automatic icon will flash during a brew cycle after the start/stop button is pressed.

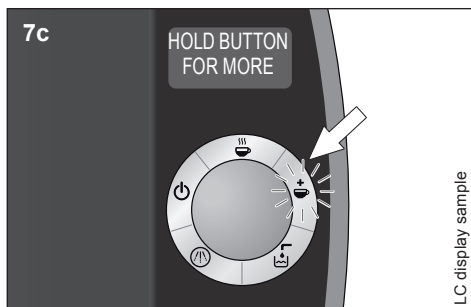

7c Manual ☕

☕ Manual icon lights up (green) when the brewing process is almost complete. If you press and hold the start/stop button within 20 seconds of the manual icon lighting up, you can extend the brewing process in order to adjust the strength of your drink. Using this manual operation will result in a milder tasting drink.

☕ Manual icon flashes during this time.

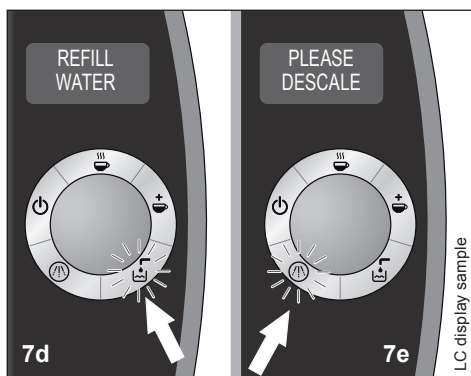

7d Fill tank 🚰

🚰 Fill tank icon flashes (red) when the removable water tank needs to be refilled. Remove the water tank, fill with water and replace it on your TASSIMO machine.

7e Descale 🚰

🚰 Descale icon lights up (red) when your TASSIMO machine needs to be descaled. Descale your appliance in accordance with the instructions provided under "Descaling".



Cup size

By adjusting the height of the cup stand, different sized cups and glasses can be used depending on your choice of drink. Use the default position for normal cups. To adjust the shelf for small cups (e.g. espresso cups), turn the height adjustment control counterclockwise until it clicks into place.

For large cups or glasses, the cup stand can be removed completely.

To avoid overflowing, select the appropriate cup size for each type of drink:

| | |
|---|---------------------|
| Espresso: | 3 oz / 85 ml |
| Filter coffee & Café Crema: | 11 oz / 325 ml |
| Cappuccino, Latte, Tea & Hot Chocolate beverages: | 11 oz / 325 ml |
| 12 oz Coffees: | min. 16 oz / 475 ml |



How to use your TASSIMO machine

Important: Fill the water tank **only** with cool, fresh, uncarbonated water each day for optimum flavor results. Tap water is ok to use. Do not use chemically softened water.

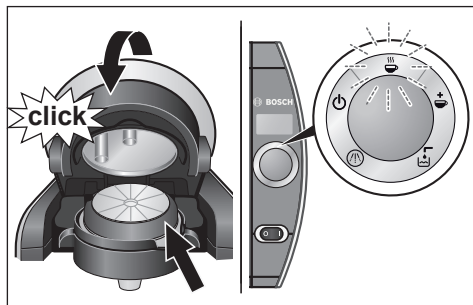

Your TASSIMO machine is ready for use. When ready, the ☺ stand-by icon is lit.

- ▶ Place a suitable cup size on the stand according to the type of drink required. Adjust the height of the stand if necessary, or remove it altogether for large cups or glasses. Make sure the distance between the top of the cup and the brewing unit is small to avoid spattering.
- ▶ Open the brewing unit by lifting the lid.
- ▶ Select a T DISC and insert it in the T DISC holder with the printed side down. Make sure that the tab of the T DISC is secured in the slot to the right.
- ▶ Close the brewing unit by pushing the lid down firmly until it clicks into place.
 - ☺ Stand-by flashes while the machine reads the barcode.
 - ☺ Automatic icon lights up (green) when your TASSIMO machine is ready to brew your drink.

Your TASSIMO machine is designed to make the optimal drink every time. It automatically brews your favorite drink, however you can also customize your drink with TASSIMO.

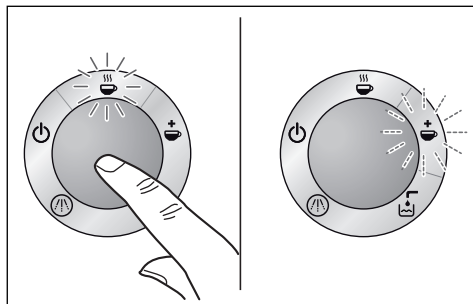

1. Automatic:

Start the brewing process by pressing the start/stop button. ☺ Automatic icon will flash. When the automatic brewing process is complete, ☺ Manual icon lights up. Your drink has been brewed for optimum flavor according to predefined settings.

2. Customized (manual operation):

- a. For a **stronger taste** and a **smaller drink**: Start the brewing process by pressing the start/stop button. ☺ Automatic icon will flash. Press the start/stop button at any stage during the brewing process to stop the process early and adjust the drink to your individual taste. Your drink is now ready. ☺ Manual icon lights up for 20 sec.

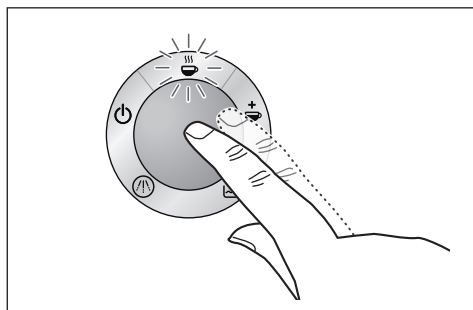

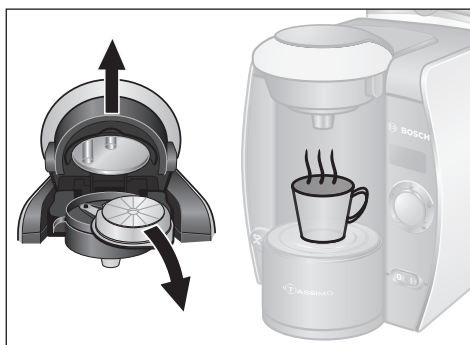
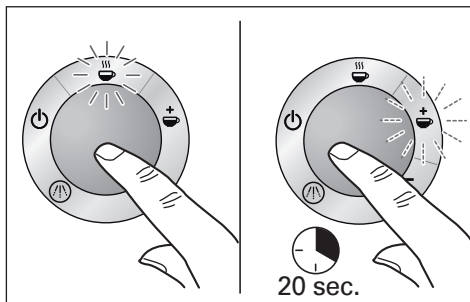

CAUTION

To avoid risk of burn or scalding:

- **Wait until orange light is displayed before opening the brewing unit.**
- Do not open the brewing unit during the brewing process.
- Do not touch the piercing unit immediately after brewing.
- Please note that the beverages are very hot when dispensed.
- T DISC is hot after brewing, please handle with care

- b. For a **milder flavor** and a **larger drink**: Start the brewing process by pressing the start/stop button. ☕ Automatic icon flashes. When the automatic brewing process is complete, ☕ Manual icon lights up. If you press and hold the start/stop button within 20 seconds, you can extend the brewing process to get your desired drink strength.

- ▶ Do not open the brewing unit to remove the T DISC until the orange stand-by light is on.
- ▶ Open the brewing unit and remove the T DISC. Now you can sit back and enjoy your hot drink. If you wish, you can prepare the next drink immediately.
- ▶ If you do not wish to prepare more drinks, we recommend that you turn off your TASSIMO machine using the on/off switch.

⚠ Note:

- ▶ There may be short pauses during the brewing process. This is so the drink flavor is optimized.
- ▶ Do not remove the water tank during the brewing process.
- ▶ Always remove the used T DISC after the brewing process after the orange standby light comes on. Be careful and hold it by the tab because the T DISC is hot after brewing your drink. When removing the T DISC, quickly flip it over so that the printed side is face up to avoid any dripping.

T DISC storage

T DISCS may be stored in their own packaging or in other containers of your choice. They should be stored in a cool, dry place. It is not necessary to store T DISCS (especially milk T DISCS) in the refrigerator. Do not keep them in the freezer. Provided the outer packaging is intact, T DISCS may be used until the Best Before date which you can find in the gold bar on the side of the foil wrap package.

Maintenance and day to day care



WARNING

To reduce risk of fire and electric shock:
*Unplug the appliance before cleaning it.
 Never immerse the appliance in water.
 Do not use a steam cleaner.*

Clean your TASSIMO machine regularly to ensure that it continues to produce optimal quality drinks. If the appliance has been

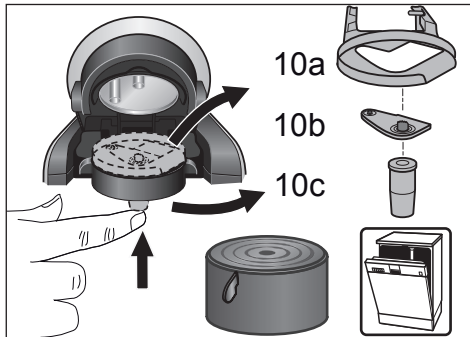
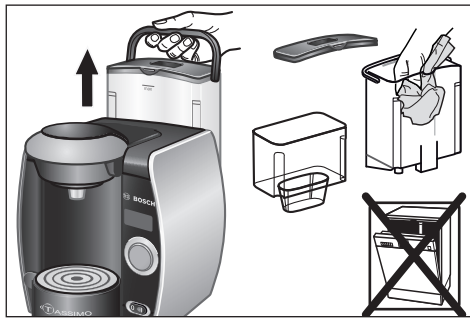
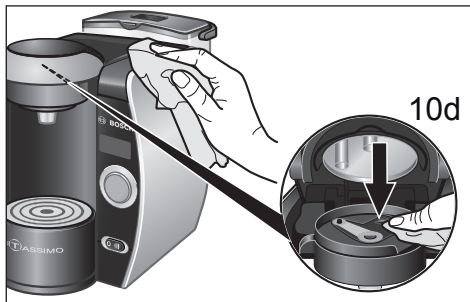

unused for a long time, always run the cleaning process with the Service T DISC several times to ensure that the drinks produced are of its normal high quality (see "First use of your TASSIMO machine"). Do not use scouring agents or steam cleaners.

- ▶ Clean the barcode scanner regularly (10d) with a soft, damp cloth, so that the TASSIMO machine can scan the barcode on the T DISC properly.
- ▶ Wipe the outside of the appliance with a soft, damp cloth.
- ▶ Rinse out the water tank and filter cartridge holder by hand and with water only, and do not place it in the dishwasher.
- ▶ The lid of the water tank cannot be cleaned in the dishwasher.
- ▶ All parts of the cup stand can be washed in the dishwasher.
- ▶ Remove the T DISC holder (10a), the piercing unit (10b) and the drink outlet (10c) and clean thoroughly. All these parts can also be cleaned in the dishwasher. When preparing a number of drinks one after another, the piercing unit may be manually cleaned quickly and easily under running water.
- ▶ We recommend that you clean the brewing unit regularly using the Service T DISC as described under "First use of your TASSIMO machine".



CAUTION

To avoid risk of burn or scalding:
 Piercing unit can be very hot immediately after brewing. Wait until it is cool before removing or cleaning

Important: After use, we recommend that the Service T DISC be stored in its compartment at the back of the appliance (11).

Note: After dispensing a milky drink or hot chocolate drink, we recommend that you first clean the piercing unit and then the brewing unit using the Service T DISC before making another drink.

Descaling

Your TASSIMO machine has an automatic descaling program. If  Descale icon lights up while the appliance is on, the descaling program must be run immediately. If the descaling process is not run as instructed, the appliance may become damaged.

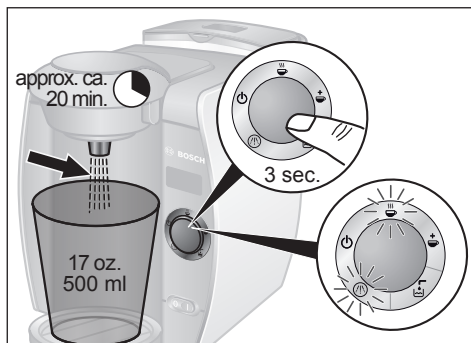
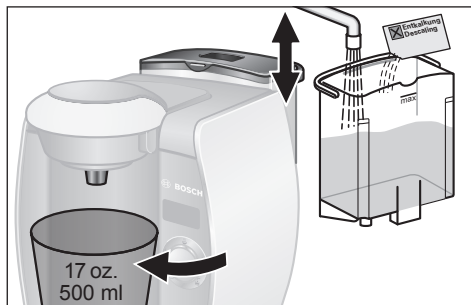
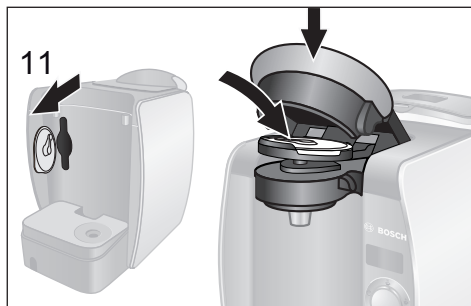

Descaling agents (not vinegar-based) can be obtained from various retailers or from TASSIMO or Bosch Customer Service Department at 1-877-TDISCS1 (1-877-834-7271) or on www.tassimo.com.

CAUTION



Do not drink the liquids.

Never interrupt the descaling program.

Never use vinegar or vinegar-based products.

Note: Only for machines with water filter
It is essential to remove the filter holder with the filter cartridge before running the descaling program.

Running the descaling program

- ▶ Remove the water tank from your TASSIMO machine and take the Service T DISC out (11). Insert it in the brewing unit with the barcode face down, and close the clamp down firmly.
- ▶ Prepare descaling solution (not vinegar-based) according to the manufacturer's instructions. If you cannot find an appropriate descaling agent at various retailers, it is available through TASSIMO or Bosch Customer Service Department.
- ▶ Replace the water tank containing the descaling solution back on the machine.
- ▶ Remove the cup stand and place a suitable container (min. 17 oz / 500 ml capacity) under the drink outlet.
- ▶ Press and hold the start/stop button for at least 3 seconds to start the descaling program.
- ▶ The program now proceeds automatically and  Descale and  Automatic lights flash. (Duration approx. 20 minutes). The descaling solution is pumped through the appliance at intervals and then runs into the container until the water tank is almost empty. A little liquid is always left in the tank.

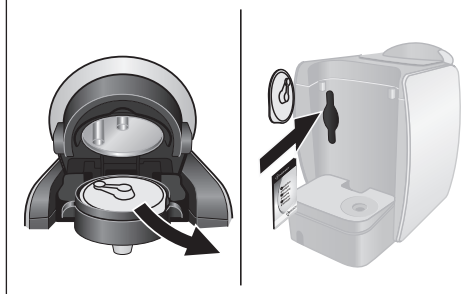
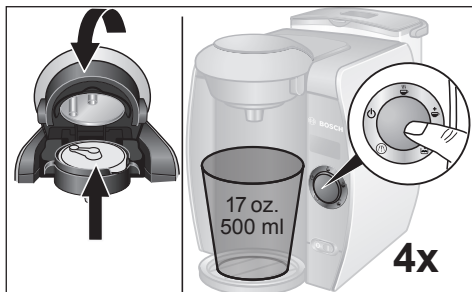
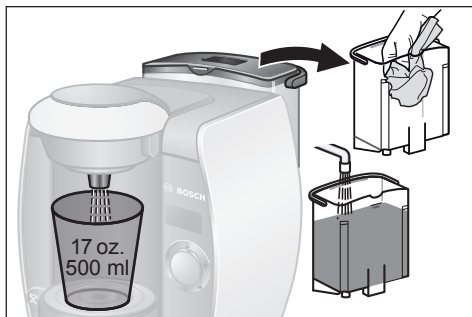

- ▶  Stand-by icon will light up after approx. 20 minutes of running descaling program.
- ▶ Empty the container and replace it under the drink outlet.
- ▶ Rinse the water tank thoroughly and fill up to the MAX mark with fresh water.
- ▶ Replace it back onto your TASSIMO machine.
- ▶ Open and close the brewing unit keeping the Service T DISC in place on the T DISC holder and press the start/stop button. The machine will rinse itself. Once one cycle is complete, press the button again repeating 4 more times. The descaling process is complete.
- ▶ Now open the brewing unit, remove the Service T DISC and store it in the compartment at the back of the machine (11).

Note: For machines with water filter

- ▶ Place the filter holder with the filter cartridge into the water tank.
- ▶ Your TASSIMO machine is ready for use again.

Important: Bosch only manufactures the TASSIMO brewer. It therefore does not guarantee the availability of TASSIMO T DISCS. For T DISC inquiries, please contact TASSIMO or Bosch Customer Service Department at 1-877-TDISCS1 (1-877-834-7271) or on www.tassimo.com

All rights reserved.

Disposal



Only for machines with water filtration system.







Important: There is a built-in battery in the memo display. It must be disposed of separately according to regulation. Please dispose of the water tank cover with the memo display at appropriate public collecting sites or at specialty retailers according to ordinances.

Troubleshooting

The following table provides solutions for problems and glitches that may arise as you use your TASSIMO machine. If you do not find a solution for your specific problem, or the problem persists after troubleshooting please contact **TASSIMO Customer Service at 1-877-TDISCS1 (1-877-834-7271)**.

⚠ Note: If piercing unit is missing, it may be purchased from TASSIMO or Bosch Customer Service Department at 1-877-TDISCS1 (1-877-834-7271) or www.tassimo.com.

| Problem | Possible cause | Solution |
|---|--|--|
| Appliance not working; no symbols light up. | There is no power supply. | Check that the appliance is properly plugged into the power supply. |
| I cannot read the LC display because it is in the wrong language. | You may want to change the language setting. | Please proceed as described in the section “Controls and displays”. |
| Machine brews but no drink dispensed. | The water tank was removed during the brewing process or there is air in the system. | Replace the water tank in the appropriate position in your TASSIMO machine. Start a cleaning process with the Service disc. |
| | The float in the water tank is stuck. | Clean the water tank and ensure the float can move. |
|  Automatic mode not working, appliance remains in stand-by mode. | No T DISC inserted. | Check if T DISC has been inserted. |
| | The barcode could not be detected. | Clean the bar code reading window and try again or smooth the barcode on the T DISC out with your thumb. |
| | | Use another T DISC. If problems persist contact TASSIMO or Bosch Customer Service Department at 1-877-TDISCS1 (1-877-834-7271). |
|  Automatic mode skipped, appliance goes straight to  manual mode. | The barcode could not be detected. | Clean the bar code reading window. |
| | | Use another T DISC. |
| | | You can still prepare the drink by holding down the start/stop button. |
| Brewing unit cannot be securely closed. | Piercing unit / T DISC holder is not properly inserted. | Insert the T DISC holder and piercing unit properly. |
| | The T DISC is not inserted properly. | Re-insert the T DISC and make sure it is properly positioned. |
| | The brewing unit is not properly closed. | Push the clamp down firmly until it audibly clicks into place. |

| Problem | Possible cause | Solution |
|--|---|--|
| Water dripping from the brewing unit. | The T DISC is damaged or leaky. | Stop the brewing process, remove the T DISC and clean the brewing unit. |
| | The piercing unit is either not inserted or not inserted properly. | Check to ensure that the piercing unit is inserted properly. |
| Water on the surface under the cup stand. | Water from condensation. | Condensation may occur and is not a fault. Remove it by wiping with a cloth. |
| Service T DISC is damaged or lost. | The Service T DISC must always be used for cleaning and descaling processes. | A Service T DISC can be purchased from www.tassimo.com or from TASSIMO or Bosch Customer Service Department at 1-877-TDISCS1 (1-877-834-7271). |
|  Fill tank lights up even though there is sufficient water in the tank. | The float in the water tank is stuck. | Clean the water tank and ensure that the float can move. |
|  7d and  7e are flashing simultaneously and it is not possible to prepare drinks. | There is an error on the machine. | Turn the machine off using the on/off switch, wait approximately 5 minutes and turn the machine back on. If  7d and  7e are still flashing, please contact the TASSIMO or BOSCH Customer Services Department at 1-877-TDISCS1 (1-877-834-7271). |
|  Descal flashes even though you are using filtered or softened water. | Even filtered water contains small amounts of dissolved lime. | Descal the appliance. |
| Memo display is not working anymore. | Reset or purchase new one. | Contact the TASSIMO or Bosch Customer Service Department at 1-877-TDISCS1 (1-877-834-7271). |
| Cup lighting and LC display have turned off | After 5 min. of inactivity, machine automatically reverts to stand-by mode to save energy | To re-activate, please open and close brewing unit or touch start/stop button |
| Can I turn off the cup lighting? | – | No, the cup lighting is automatically switched on and off when the machine is activated. |

STATEMENT OF LIMITED PRODUCT WARRANTY

Tassimo by Bosch

What this Warranty Covers & Who it Applies to: The limited warranty provided BSH Home Appliances Bosch in this Statement of Limited Product Warranty applies only to the Tassimo by Bosch ("Product") sold to you, the first using purchaser, provided that the Product was purchased: (1) for your normal, household (non-commercial) use, and has in fact at all times only been used for normal household purposes; (2) new at retail (not a display, "as is", or previously returned model), and not for resale, or commercial use; and (3) within the United States or Canada, and has at all times remained within the country of original purchase. The warranties stated herein apply only to the first purchaser of the Product and are not transferable.

- Please make sure to return your registration card; while not necessary to effectuate warranty coverage, it is the best way for Bosch to notify you in the unlikely event of a safety notice or product recall.

How Long the Warranty Lasts: Bosch warrants that the Product is free from defects in materials and workmanship for a period of three hundred sixty-five days (365) days from the date of purchase. The foregoing timeline begins to run upon the date of purchase, and shall not be stalled, tolled, extended, or suspended, for any reason whatsoever.

Repair/Replace as Your Exclusive Remedy: During this warranty period, Bosch or one of its authorized service providers will repair your Product without charge to you (subject to certain limitations stated herein) if your Product proves to have been manufactured with a defect in materials or workmanship. If reasonable attempts to repair the Product have been made without success, then Bosch will replace your Product (upgraded models may be available to you, in Bosch's sole discretion, for an additional charge). All removed parts and components shall become the property of Bosch at its sole option. All replaced and/or repaired parts shall assume the identity of the original part for purposes of this warranty and this warranty shall not be extended with respect to such parts. Bosch's sole liability and responsibility hereunder is to repair manufacturer-defective Product only, using a Bosch-authorized service provider during normal business hours. For safety and property damage concerns, Bosch highly recommends that you do not attempt to repair the Product yourself, or use an un-authorized servicer; Bosch will have no responsibility or liability for repairs or work performed by a non-authorized servicer. If you choose to have someone other than an authorized service provider work on your Product, THIS WARRANTY WILL AUTOMATICALLY BECOME NULL AND VOID. Authorized service providers are those persons or companies that have been specially trained on Bosch products, and who possess, in Bosch's opinion, a superior reputation for customer service and technical ability (note that they are independent entities and are not agents, partners, affiliates or representatives of Bosch). Notwithstanding the foregoing, Bosch will not incur any liability, or have responsibility, for the Product if it is located in a remote area (more than 100 miles from an authorized service provider) or is reasonably inaccessible, hazardous, threatening, or treacherous locale, surroundings, or environment; in any such event, if you request, Bosch would still pay for labor and parts and ship the parts to the nearest authorized service provider, but you would still be fully liable and responsible for any travel time or other special charges by the service company, assuming they agree to make the service call.

Out of Warranty Product: Bosch is under no obligation, at law or otherwise, to provide you with any concessions, including repairs, pro-rates, or Product replacement, once this warranty has expired.

Warranty Exclusions: The warranty coverage described herein excludes all defects or damage that are not the direct fault of Bosch, including without limitation, one or more of the following: (1) use of the Product in anything other than its normal, customary and intended manner (including without limitation, any form of commercial use, use or storage of an indoor product outdoors, use of the Product in conjunction with air or water-going vessels); (2) any party's willful misconduct, negligence, misuse, abuse, accidents, neglect, improper operation, failure to maintain, improper or negligent installation, tampering, failure to follow operating instructions, mishandling, unauthorized service (including self-performed "fixing" or exploration of the appliance's internal workings); (4) adjustment, alteration or modification of any kind; (5) a failure to comply with any applicable state, local, city, or county electrical, plumbing and/or building codes, regulations, or laws, including failure to install the product in strict conformity with local fire and building codes and regulations; (6) ordinary wear and tear, spills of food, liquid, grease accumulations, or other substances that accumulate on, in, or around the Product; and (7) any external, elemental and/or environmental forces and factors, including without limitation, rain, wind, sand, floods, fires, mud slides, freezing temperatures, excessive moisture or extended exposure to humidity, lightning, power surges, structural failures surrounding the appliance, and acts of God. In no event shall Bosch have any liability or responsibility whatsoever for damage to surrounding property, including cabinetry, floors, ceilings, and other structures or objects around the Product. Also excluded from this warranty are scratches, nicks, minor dents, and cosmetic damages on external surfaces and exposed parts; Products on which the serial numbers have been altered, defaced, or removed; service visits to teach you how to use the Product, or visits where there is nothing wrong with the Product; correction of installation problems (you are solely responsible for any structure and setting for the Product, including all electrical, plumbing or other connecting facilities, for proper foundation/flooring, and for any alterations including without limitation cabinetry, walls, floors, shelving, etc.); and resetting of breakers or fuses. **TO THE EXTENT ALLOWED BY LAW, THIS WARRANTY SETS OUT YOUR EXCLUSIVE REMEDIES WITH RESPECT TO PRODUCT, WHETHER THE CLAIM ARISES IN CONTRACT OR TORT (INCLUDING STRICT LIABILITY, OR NEGLIGENCE) OR OTHERWISE. THIS WARRANTY IS IN LIEU OF ALL OTHER WARRANTIES, WHETHER EXPRESS OR IMPLIED. ANY WARRANTY IMPLIED BY LAW, WHETHER FOR MERCHANTABILITY OR FITNESS FOR A PARTICULAR PURPOSE, OR OTHERWISE, SHALL BE EFFECTIVE ONLY FOR THE PERIOD THAT THIS EXPRESS LIMITED WARRANTY IS EFFECTIVE. IN NO EVENT WILL THE MANUFACTURER BE LIABLE FOR CONSEQUENTIAL, SPECIAL, INCIDENTAL, INDIRECT, "BUSINESS LOSS", AND/OR PUNITIVE DAMAGES, LOSSES, OR EXPENSES, INCLUDING WITHOUT LIMITATION TIME AWAY FROM WORK, HOTELS AND/OR RESTAURANT MEALS, REMODELLING EXPENSES IN EXCESS OF DIRECT DAMAGES WHICH ARE DEFINITELY CAUSED EXCLUSIVELY BY Bosch, OR OTHERWISE. SOME STATES DO NOT ALLOW THE EXCLUSION OR LIMITATION OF INCIDENTAL OR CONSEQUENTIAL DAMAGES, AND SOME STATES DO NOT ALLOW LIMITATIONS ON HOW LONG IMPLIED WARRANTY LASTS, SO THE ABOVE LIMITATIONS MAY NOT APPLY TO YOU. THIS WARRANTY GIVES YOU SPECIFIC LEGAL RIGHTS, AND YOU MAY ALSO HAVE OTHER RIGHTS, WHICH VARY FROM STATE TO STATE.** No attempt to alter, modify or amend this warranty shall be effective unless authorized in writing by an officer of BSH.

How to Obtain Warranty Service: To obtain warranty service for your Product, you should contact the nearest Bosch authorized service center.

BSH Home Appliances

5551 McFadden Avenue, Huntington Beach, CA 92649 / 800-944-2904